



Counter Console Collection Block Console

Surface-mounted washbasins and double counters in white cultured marble, with contrasting powder-coated metal console table, in a variety of colours.



Description

The modern and contemporary Block console provides an all-in-one vanity solution, with option to customise the unit length and basin cut-outs.

Counters are manufactured at 20mm thick, with front fascia at 100mm high. Available as a single, double or multiple floorstanding unit.

Metal console unit includes side towel rails and is supplied in a variety of colours.

Surface-mounted Bowl Size

Cube: L 465 | W 430 | H 100

External Console Dimensions

Length 600 - 2000 (includes counter & console)

Width 500

Fascia 100

Powder-coat Console Colours

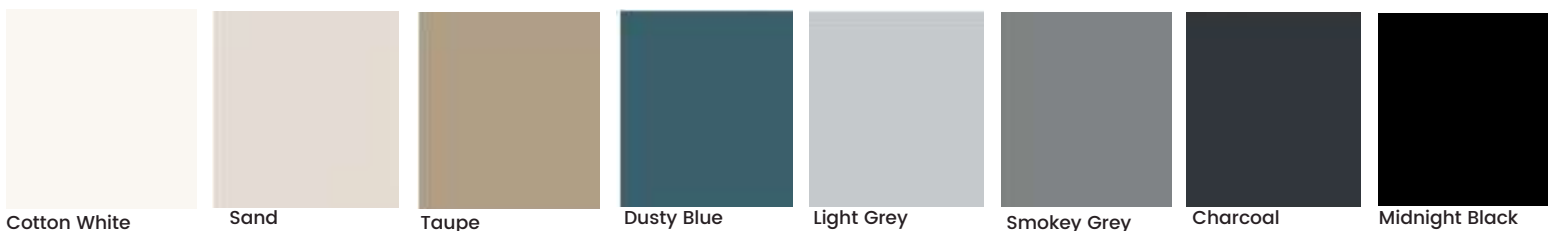

Applications showcasing single | double units.



Single Console Front Elevation



Single Console Perspective



Double Console Front Elevation



Single Console | 3D line drawings

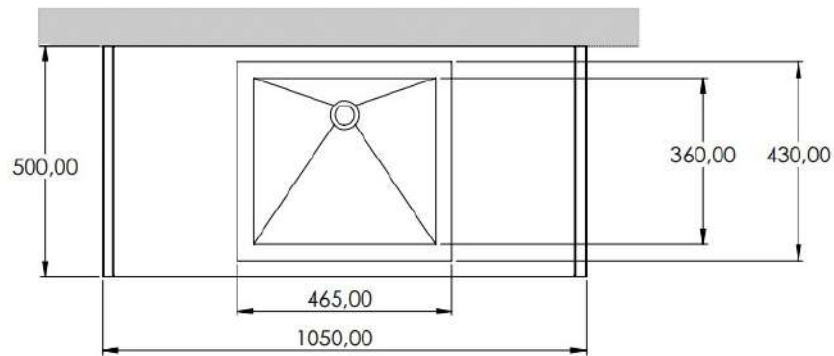

A

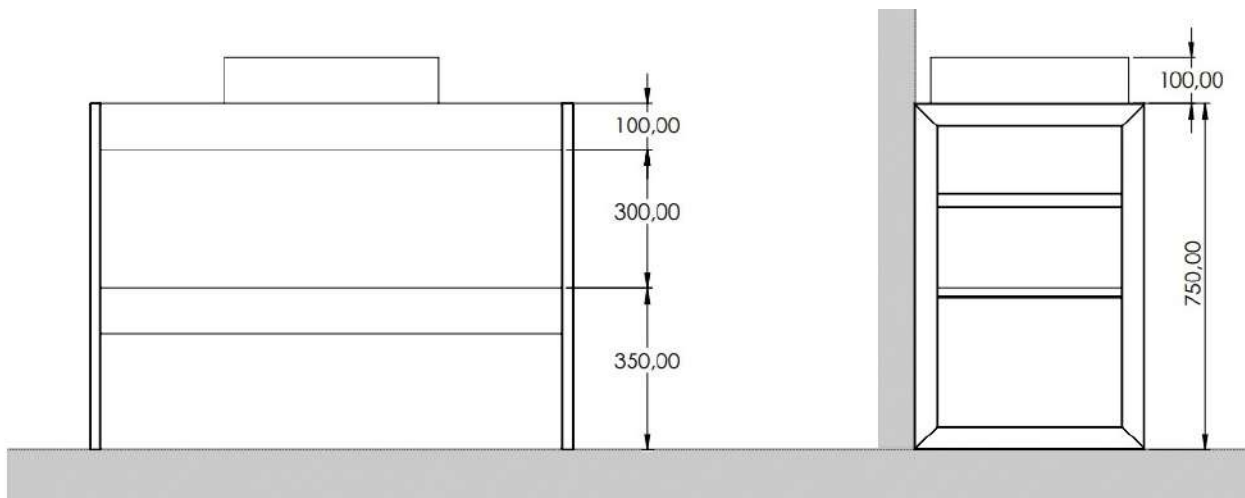

B

C

- A Plan of Block Single Console
- B Front Elevation of Block Single Console
- C Side Elevation of Block Single Console



Double Console | 3D line drawings

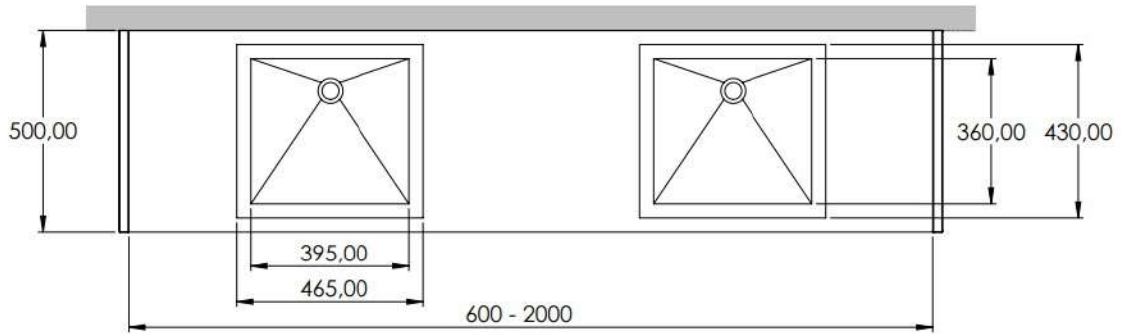

A

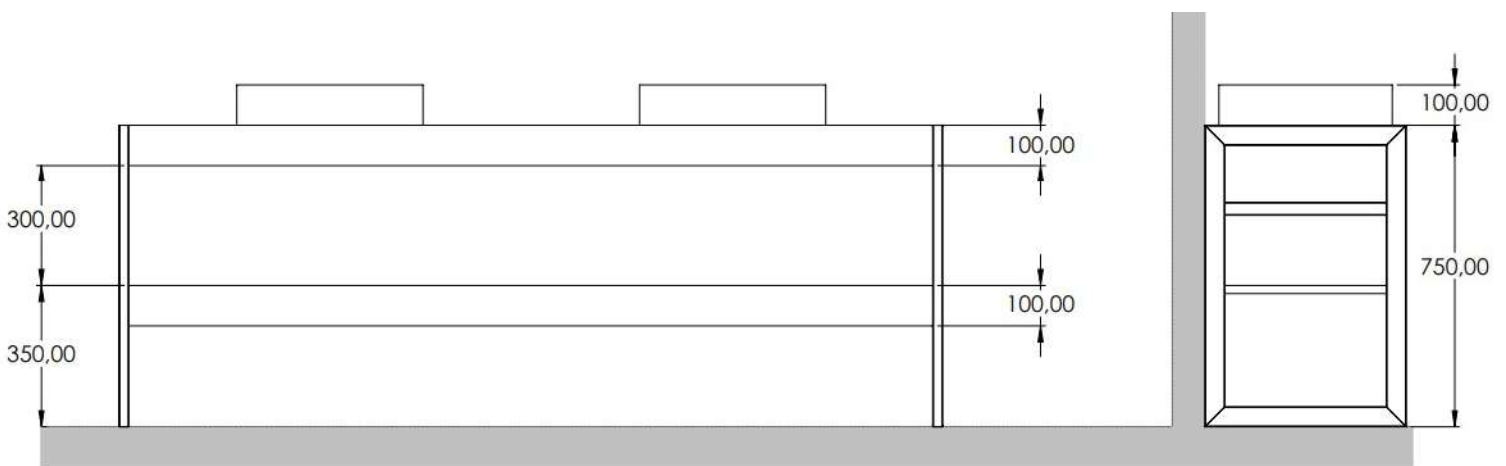

B

C

- A Plan of Block Double Console
- B Front Elevation of Block Double Console
- C Side Elevation of Block Double Console



Material & Care Tips

Marblecast surface mount basins and counters are made from a mixture of crushed marble and resin - 80% marble and 20% resin.

The material is mixed together and a small amount of catalyst is added.

The catalyst reacts with the resin and ensures that the resin polymerizes and hardens into a hard, strong mass.

This mass is then moulded into highly durable bathroom ware.

White marble has been polished to a high gloss.

Clean with a soft cloth or sponge using soap or mild detergent and warm water.

The use of abrasive pads or chemical abrasives will dull the product over time.

The thermostat in the hot water cylinder should be set at 60-65 degrees Celsius.

It is recommended to first run cold water into the bowl with a plug followed by the hot water. This will allow the marble to warm up slowly and ensure the longevity and attractiveness of the product.

Stains can be removed by hand with a white polishing compound.

Metal Consoles are supplied in a variety of powder-coat colours.

